

THE *Best* MEN'S TIE PATTERN



Redefine the cliché Father's Day gift by making it handmade! This tie will be sure to please any guy on your list.

A few notes about style:

1. This tie is thicker than your store-bought silk ties which means that your recipient will not be able to use a double windsor knot with it. Singles only!

2. Because of #1, the tie takes more bulk to make a knot, so even though it is standard length, it ends up being a bit shorter than a standard tie. You'll need to adjust the pattern where indicated if your guy is taller than average (approximately 5'10").

3. Because ties are cut on the bias (or on a 45° angle), you need to pay special attention as you're choosing fabrics. Tilt your head or the bolt of fabric 45° as you're looking to know how it will look on the tie.

designed by Georgia Solorzano ©PukingPatterns 2010
all rights reserved

Materials



Tie fabric: 5/8 yard

[suggested fabric: designer cottons, (I used Amy Butler), home dec satten cot-
tons, lightweight suiting]

Lining fabric: 5/8 yard

[suggested fabrics: lightweight cotton (I used Kona cotton), apparel lining fabric]

Lightweight interfacing: 1 yard

Assembling the PDF

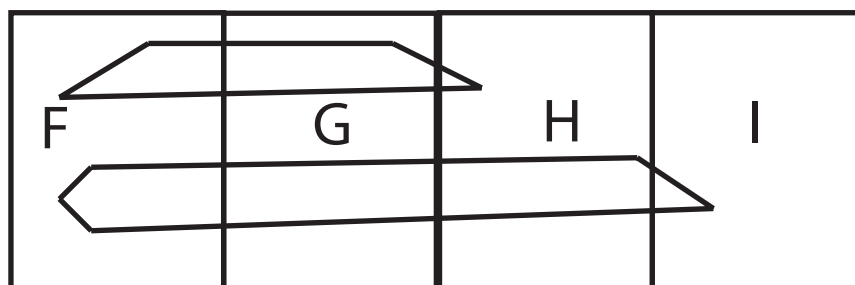
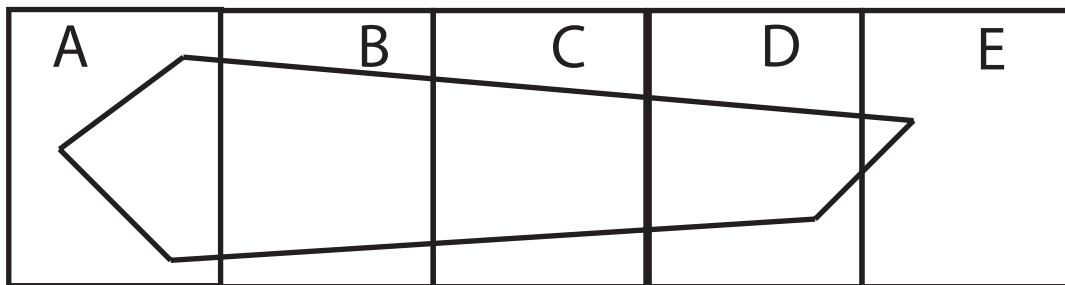

Print the pattern pieces on your home computer. In the print window, check all the settings to make sure that the printer will not resize or reshape the pattern pieces as it prints them. This usually comes in the form of "Fit to Print Area" or "Page Scaling" or might be a

percentage [100% being the percentage you want].

Arrange the pattern pieces as shown above. Cut along the dotted lines on every other page. Tape the pages together.

A

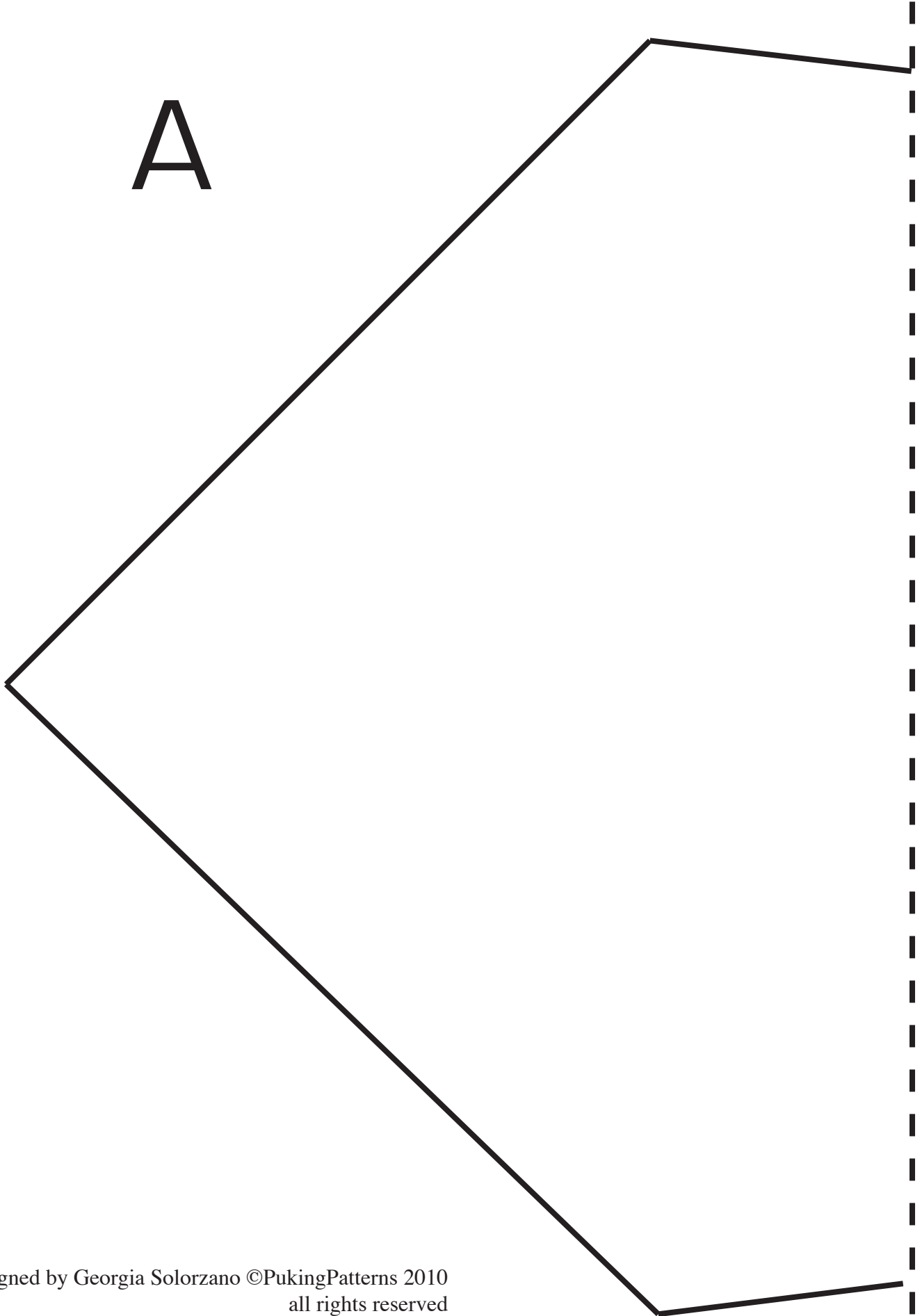

B

1

Cut 1 of Fabric
Cut 1 of Lining
Cut 1 of Interfacing



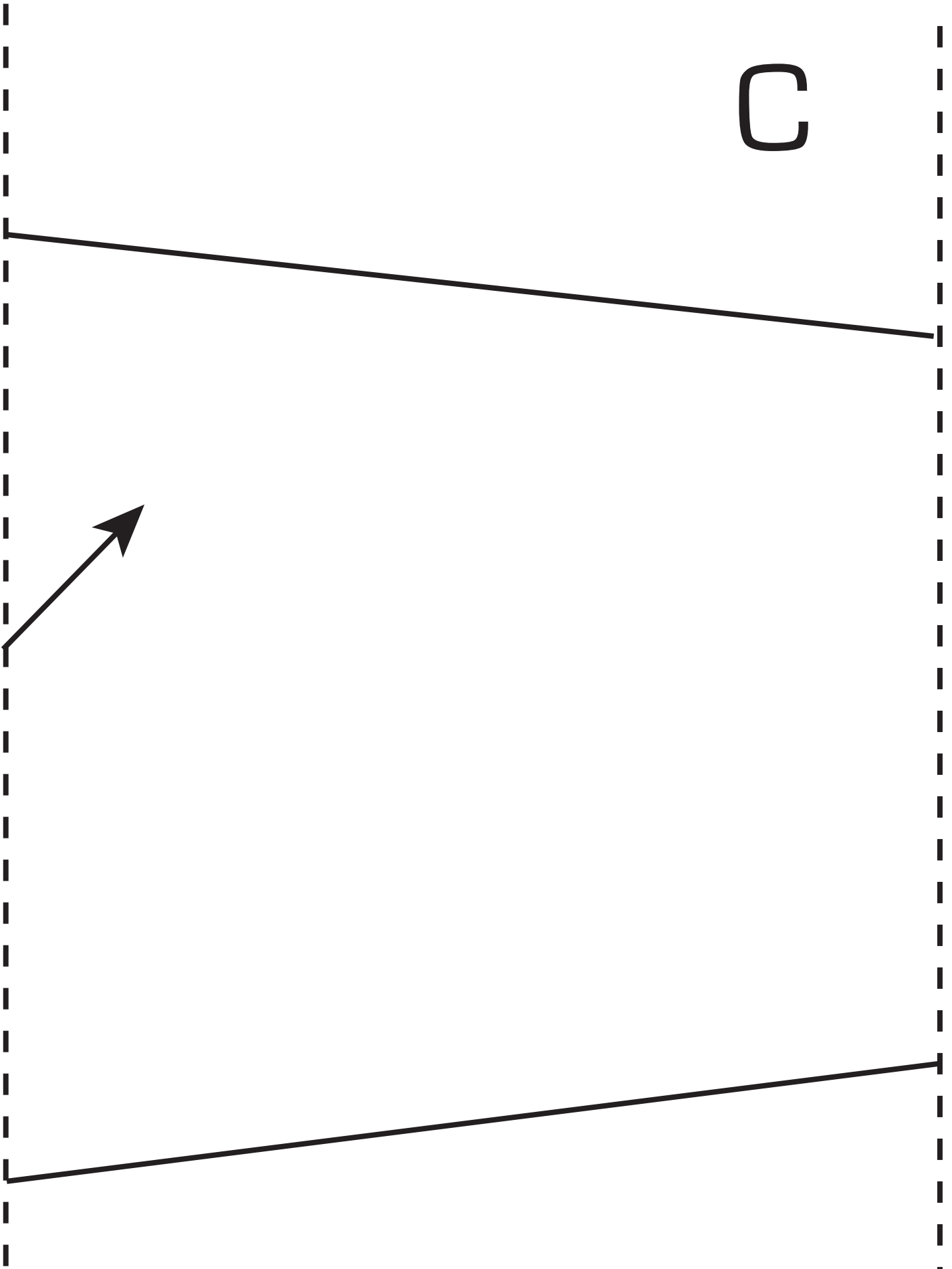

D

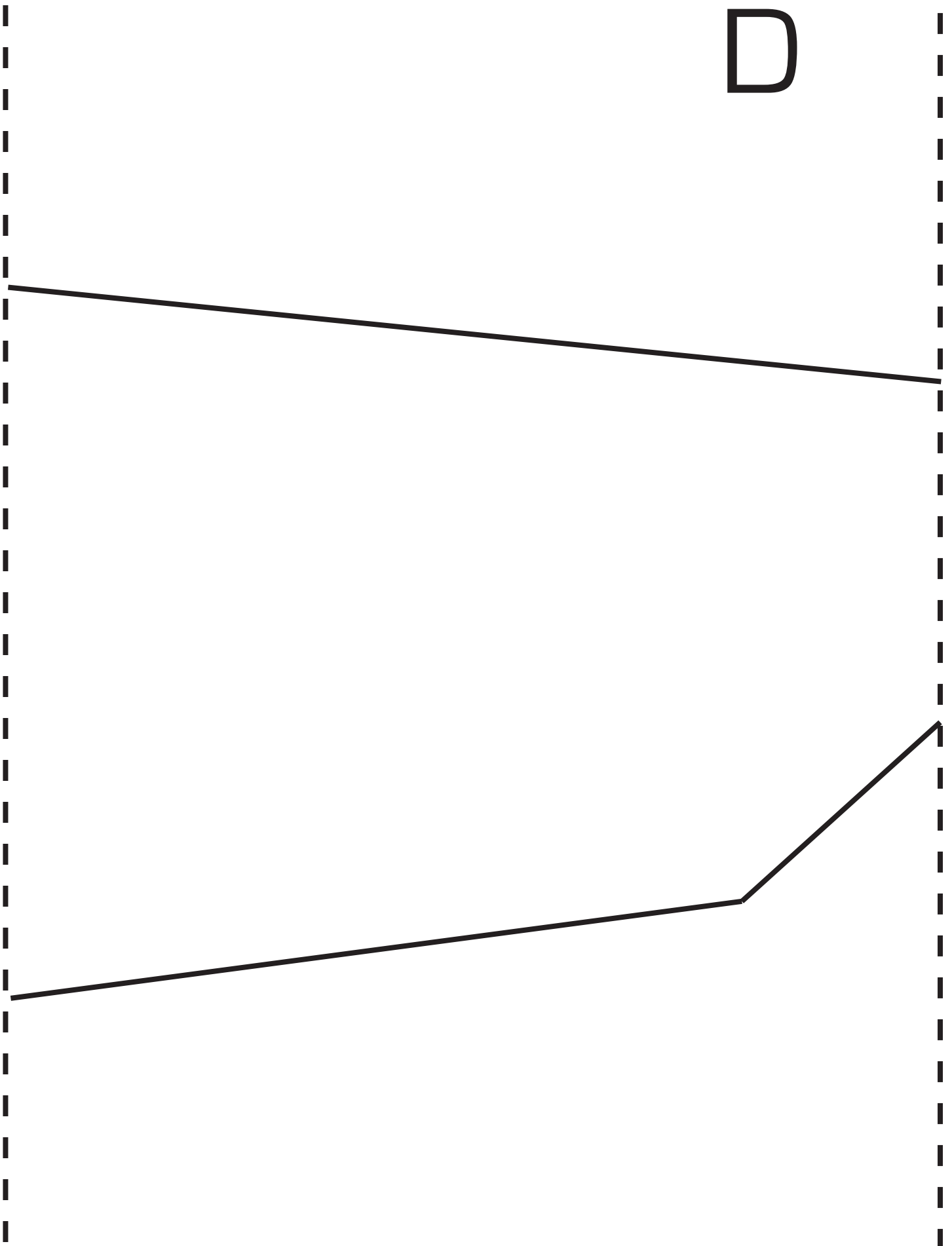



E

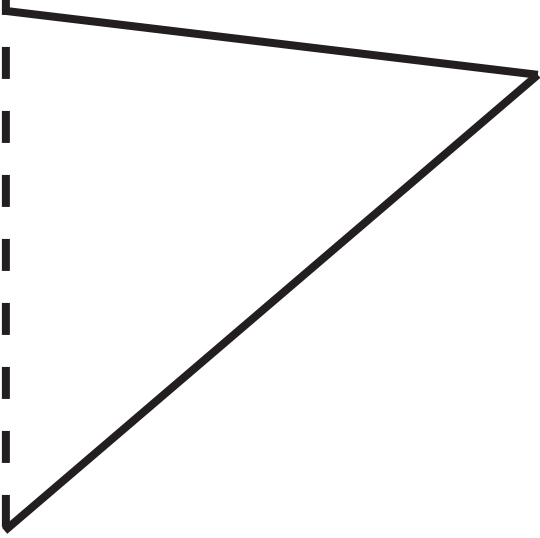

F

This end attaches to Piece 1

Lengthen Here

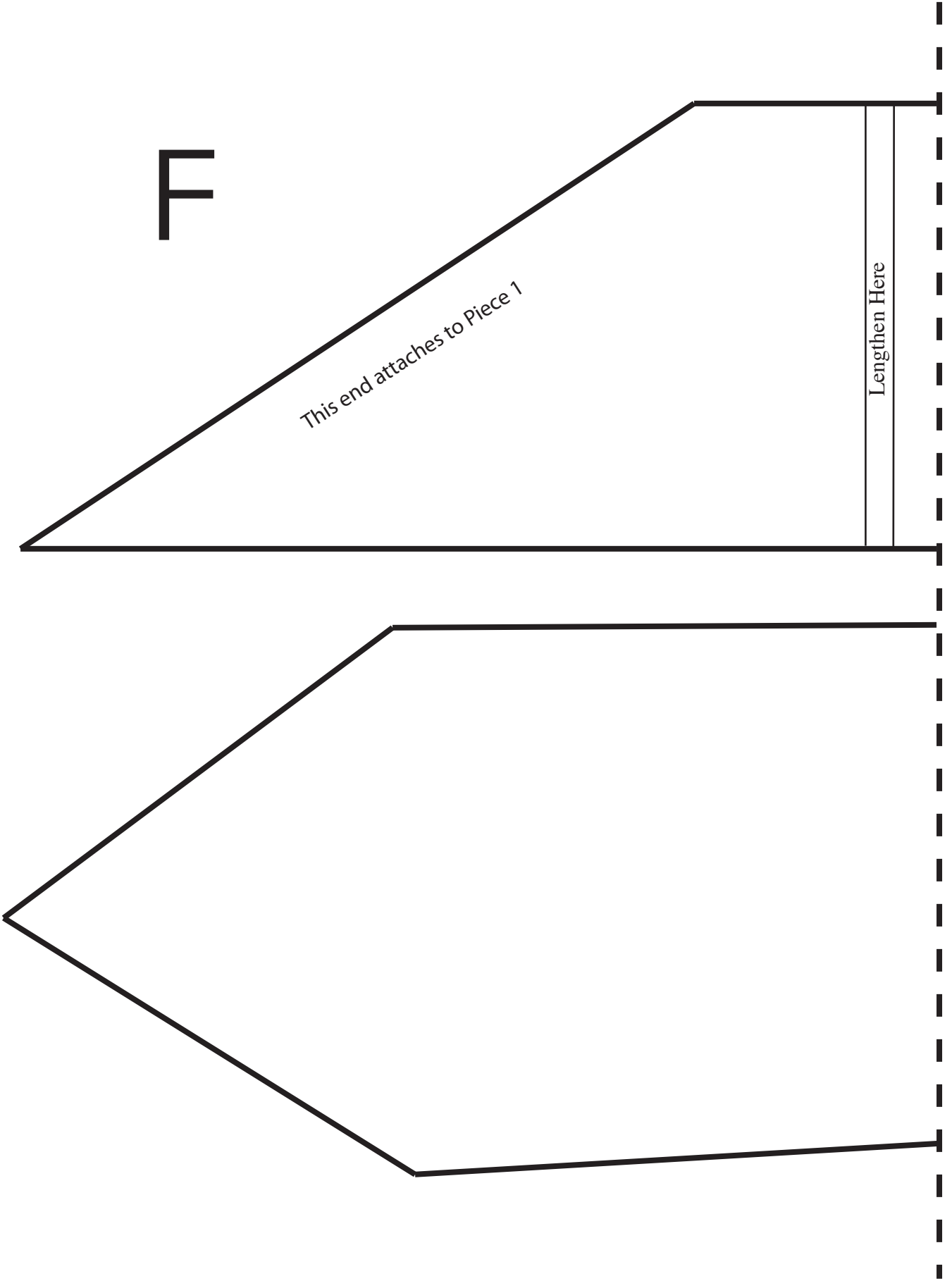

G

This end attaches to Piece 3

2

Cut 1 of Fabric
Cut 1 of Lining
Cut 1 of Interfacing

Place on grain of fabric

3

Cut 1 of Fabric
Cut 1 of Lining
Cut 1 of Interfacing



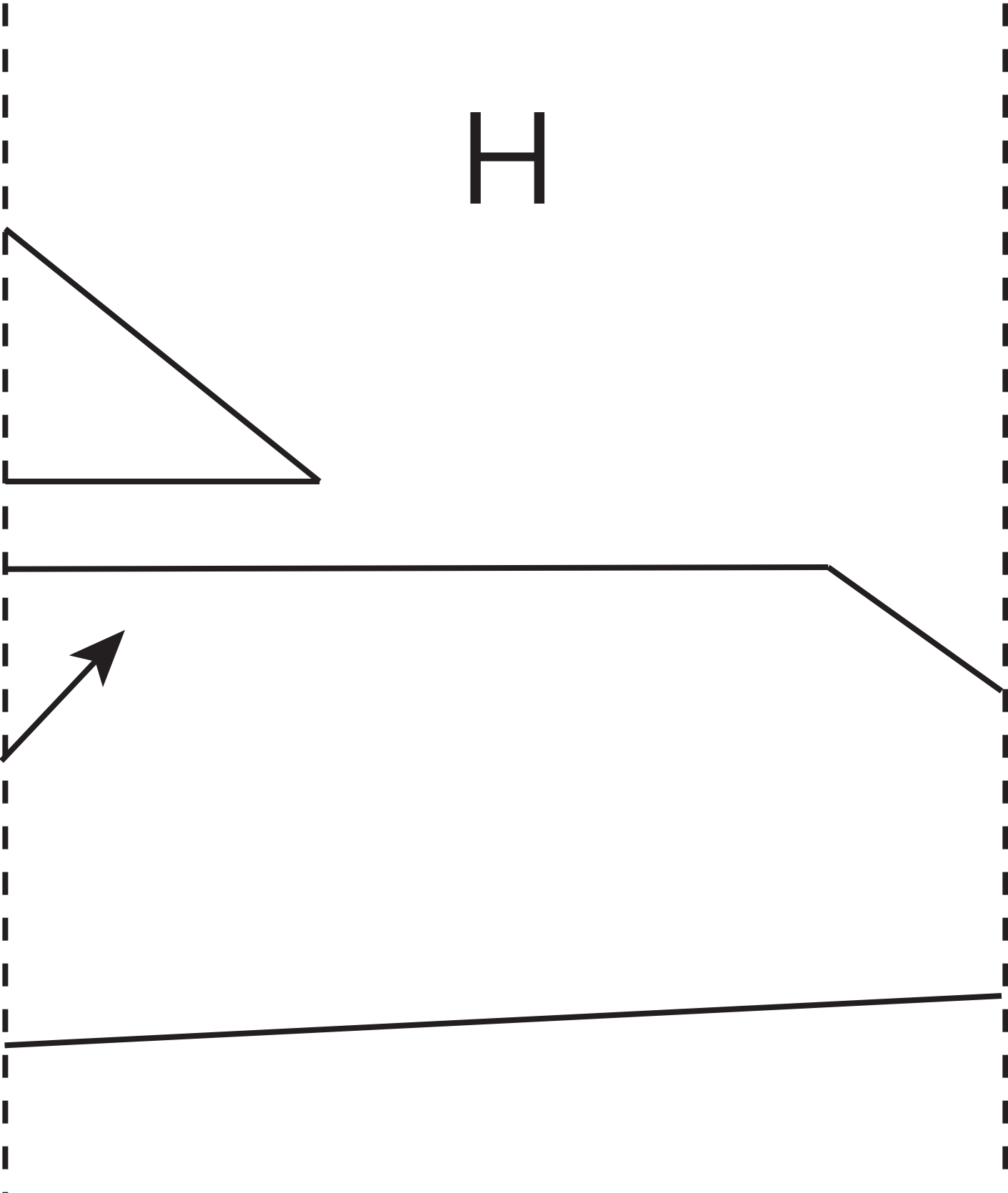

Place on grain of fabric

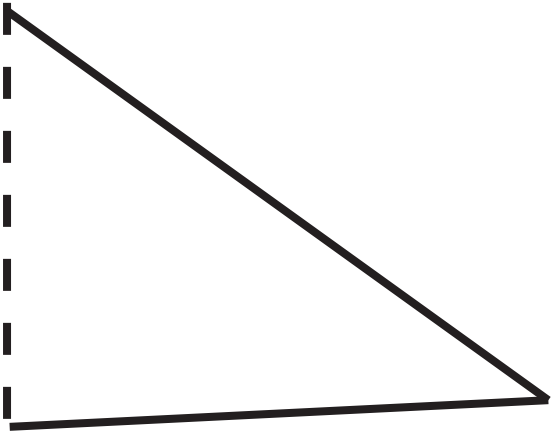

I



Legend

	-right side of fabric		-lining
	-wrong side of fabric		-interfacing

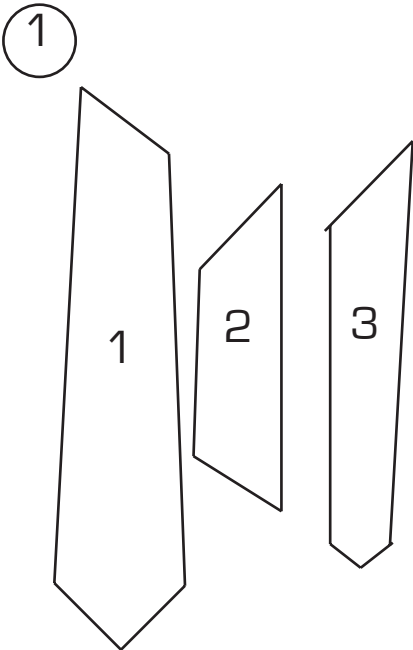

After assembling the PDF pieces, cut apart the three pattern pieces from each other.

If your favorite guy is taller than 5'10" or has a long torso, lengthen the pattern where indicated on Piece 2.

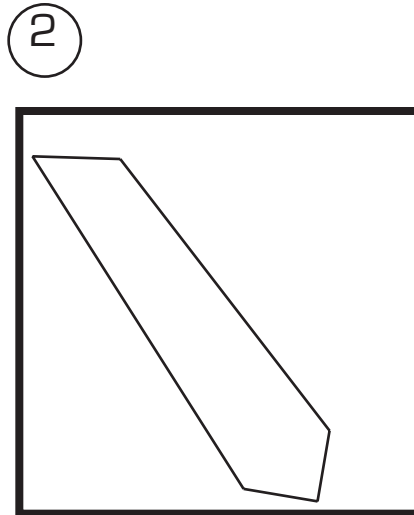

Each piece should be placed on the bias (or on a 45° angle) before cutting. The pattern pieces have a guide to help you with the bias placement.

Cut ONE of each from fabric, one of each from lining, and one of each from interfacing.

NOTE: interfacing has no grain, so the orientation when cutting is unimportant.

3

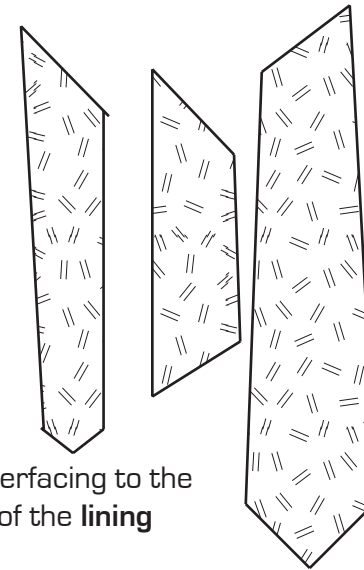

Fuse the interfacing to the wrong side of the **lining** pieces.

4

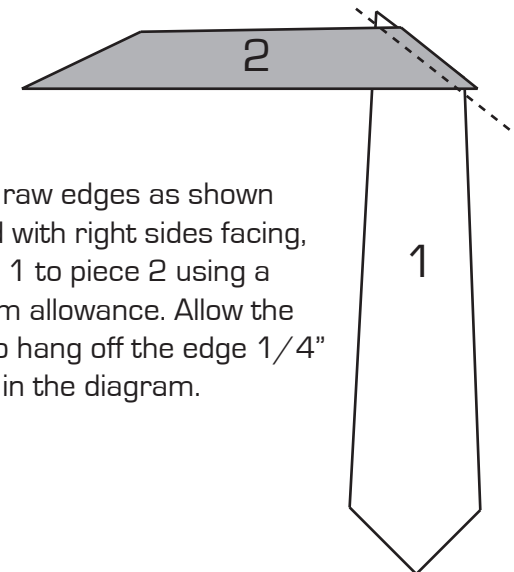

Matching raw edges as shown above and with right sides facing, sew piece 1 to piece 2 using a 1/4" seam allowance. Allow the corners to hang off the edge 1/4" as shown in the diagram.



designed by Georgia Solorzano ©PukingPatterns 2010
all rights reserved

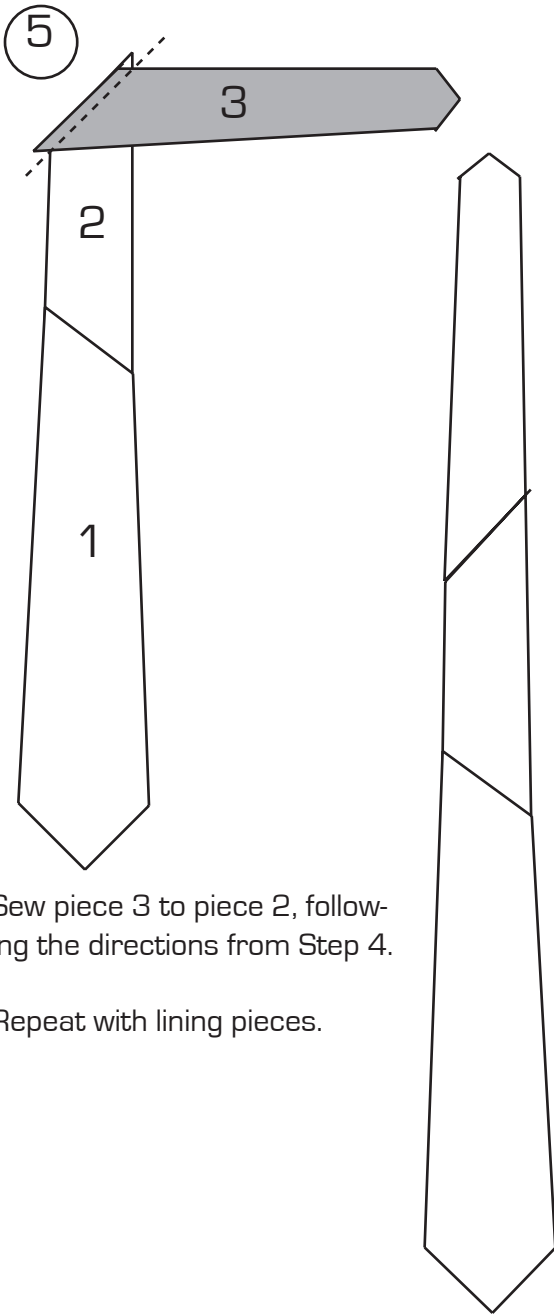

Sew piece 3 to piece 2, following the directions from Step 4.

Repeat with lining pieces.

6

With right sides facing, pin the fabric to the lining. Sew the top and bottom as shown.

Clip the points and turn right side out.

Press.

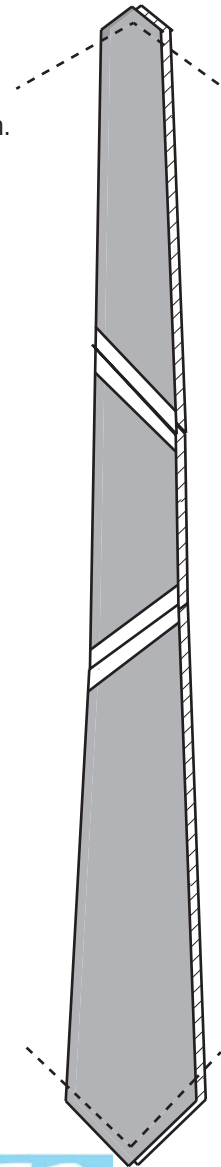

7

Baste the long raw edges of the fabric and lining together as shown using a 1/2" seam allowance.

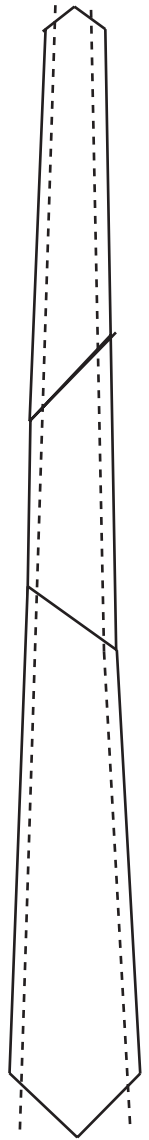

designed by Georgia Solorzano ©PekingPatterns 2010
all rights reserved

8

With the lining facing up, Fold up the right long side 1/2" using the basting stitches as a guide. Press

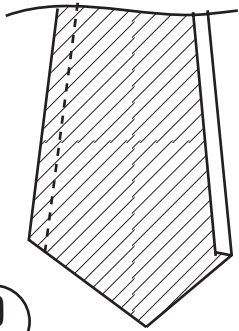

9

Fold the left long side in to the middle of the tie aligning the basting stitches with the center of the tie. Press.

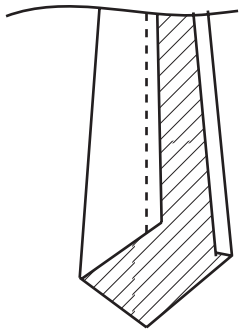

10

Fold in the right side again, This time placing the fold of the right side directly on top of the basting stitches of the left side. Press.

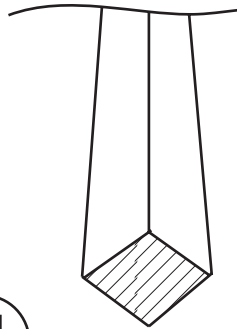

11

Hand stitch the opening closed. A ladder stitch or blind stitch would work well.

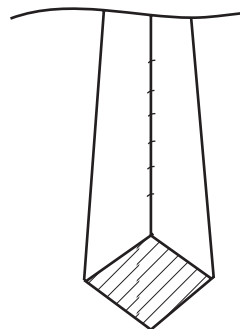

12

Press the tie.

Sewing by hand, add a piece of ribbon to hold the small end of the tie in place.

Enjoy!

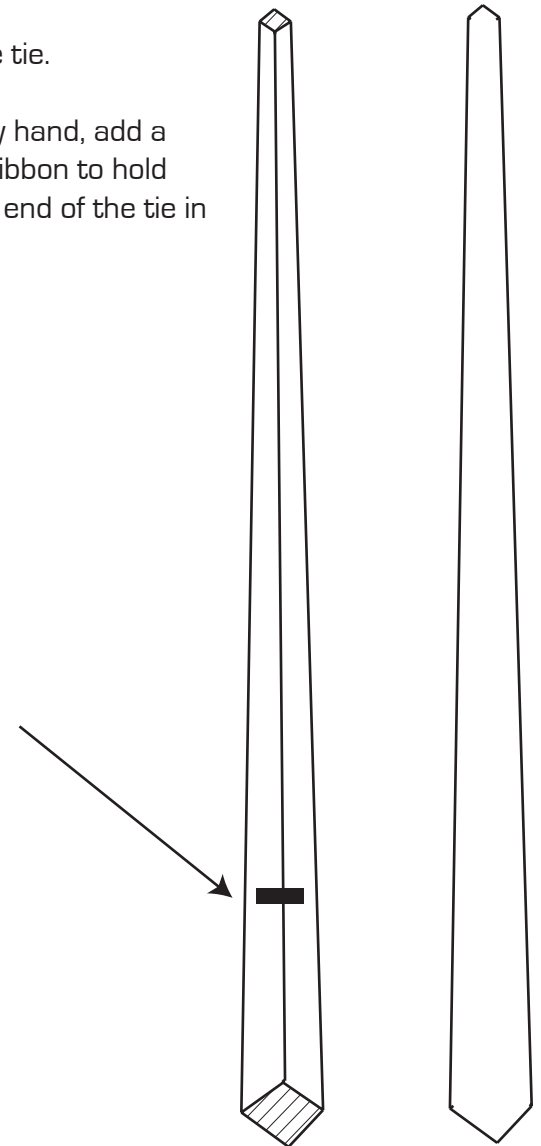

designed by Georgia Solorzano ©PukingPatterns 2010
all rights reserved